

## Type CB-1 Crane Bin

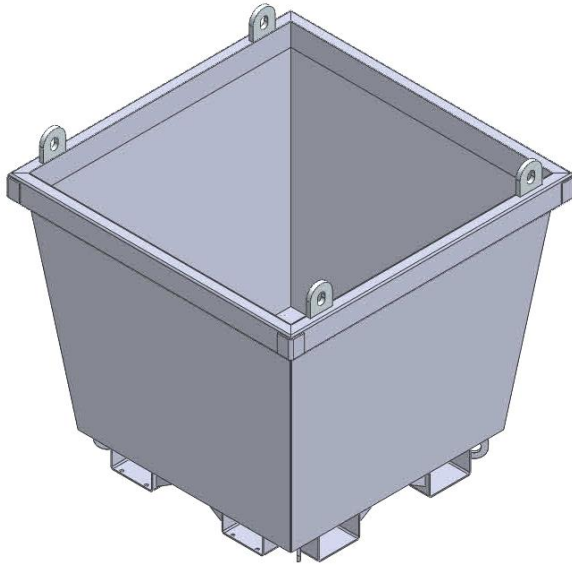

The type CB-1 Crane Bin has been designed with space saving contours to allow the bins to interlock for transport and storage and is suitable for all waste products. All bins are fitted with 4-way entry fork pockets allowing emptying by rotating Forklift from all sides, or positive handling on uneven ground. Four Crane Lugs are fitted along with upending lugs for Crane emptying.

All type CB-1 Bins have a Working Load Limit of 2000kg manufactured from 3mm steel plate. Three sizes are available with 0.85, 1.3 and 2.5 cubic metre capacities.

The standard finish on the type CB-1 Bins is Hot Dip Galvanised.

### SPECIFICATIONS:

- Working Load Limit: 2000kg
- Unit Weight – refer Table
- Volume Capacity – refer Table
- Pocket Sizes: 160 x 95 & 160 x 75mm
- Pocket Centres - refer Table

### OPTIONS:

- Wheels, Lid
- Drain Valve

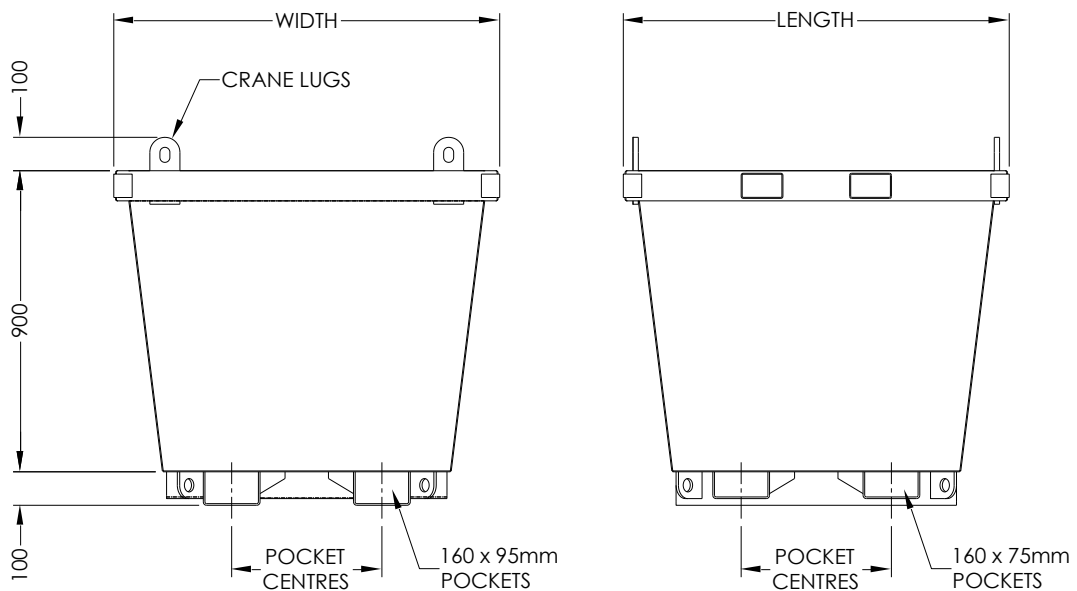

BIN TYPE	VOLUME CAPACITY	BIN WIDTH	BIN LENGTH	POCKET CENTRES	UNIT WEIGHT
CB-1	0.85m <sup>3</sup>	1156mm	1156mm	450mm	162kg
CB-2	1.3m <sup>3</sup>	1716mm	1156mm	450mm	240kg
CB-3	2.5m <sup>3</sup>	2316mm	1516mm	790mm	335kg